

Medical Device Testing Explained

Introduction

The Associated Research Inc. MedTEST system is designed to perform electrical safety testing on multiple patient lead medical devices. The system is a compilation of several Associated Research Inc safety testers that work in tandem with the Autoware software program for an automated test setup. Hipot, ground bond, and line leakage tests are a few of the safety sequences the system can run on multiple leads in order to test medical devices. The electrical safety tests the unit provides adhere to various medical standards including IEC 60601-1 and EN 60601-1. This paper will introduce the Associated Research Inc. MedTEST system and discuss options for selecting a system that is optimal for customer applications.

Types of Medical Tests

As mentioned above, the MedTEST system is designed to conform to IEC 60601-1 in reference to hipot, ground bond, functional run, insulation resistance, and line leakage testing. It includes the necessary measuring devices for line leakage testing and can be set to test for B-Type, BF Type, and CF Type applied parts. A measuring device is a circuit that is designed to represent the network of the human body. It is a way to measure the amount of leakage current that could travel through a person in the event of a failure. The measuring devices built in for touch current or line leakage testing conform to standards UL544NP, UL544P, IEC60601 (UL2601), UL1563, IEC60990 (FIG 4-U2, IEC60950), IEC60990 (FIG 5-U3). There is also an additional port for an external MD PCB. The instrument is capable of measuring either peak or RMS values. The system also has the ability to control an AC power source for applications that require more than the main voltage. The system has a variety of designs depending upon the device under test and specific product needs.

The types of medical tests that must be performed to conform to safety standards include hipot, ground bond, and several types of line leakage tests. A hipot test, also known as a dielectric withstand test, applies high voltage in order to stress the insulation of a device far past what it would encounter during normal use. The basic idea behind this test is that if the device or patient lead can withstand this high level of voltage for a given period of time, it will be able to function optimally at its normal operating voltage. IEC 60601-1 specifies various test voltages for insulation types. For most insulation types, between 1500-4000V must be applied for a dielectric withstand test. Ground bond testing is another test type to consider. A ground bond test is designed to test the integrity of the safety ground circuit of a device in order to determine if the device can handle fault current in the event of an insulation failure. Certain versions of standard 60601 specify ground bond testing such as IEC 60601 while others do not such as UL 60601. The other

test types that take fault currents into account are line leakage tests. There are several types of line leakage tests for medical devices depending upon the orientation of the measuring device. The types are earth leakage, enclosure leakage, general patient leakage, auxiliary patient leakage, and mains voltage to applied part leakage. Earth leakage is a measure of the total leakage that could flow through a product. Enclosure leakage is current that could flow through the enclosure or case of a device. General patient leakage is the type of current on a patient lead that occurs under normal and fault conditions. Conversely, auxiliary patient leakage tests leakage in a patient lead if another patient lead happens to fail. It is utilized for patient lead to patient lead testing. The last type of common leakage test for medical patient leads is a mains voltage to applied part test. This tests leakage in a patient when 110% of the mains input voltage is applied to the patient lead through the MD circuit. Most standards including IEC 60601 specify line leakage tests to be done at 110% rated voltage.

IEC 60601-1 is the international standard that requires manufacturers of medical products to conform and adhere to stringent safety practices. It was designed in order to address the risks that are commonly related to electrical medical equipment. Most electrical medical devices have contact with a device operator, a patient, or both. In either case, the device must be properly tested to ensure that excessive leakage current does not dissipate from the device enclosure or applied parts through a human body. Standard 60601-1-2.1.5 defines an applied part as “A part of the equipment which in normal use necessarily comes into physical contact with the patient for the equipment to perform its function or can be brought into contact with the patient or needs to be touched by the patient.” Since these applied parts or patient leads come into contact with a human body, measurements must be taken to ensure that electrical shock does not occur for any applied part type.

Within the realm of applied parts there are several different types depending upon the specific degree of contact with a patient. B Type applied parts are generally not conductive and can be immediately released from a patient. B Type applied parts can also be grounded. Figure 1 illustrates a B Type applied part for measuring patient auxiliary current with all patient leads tied together. Note that the reference point can be grounded.

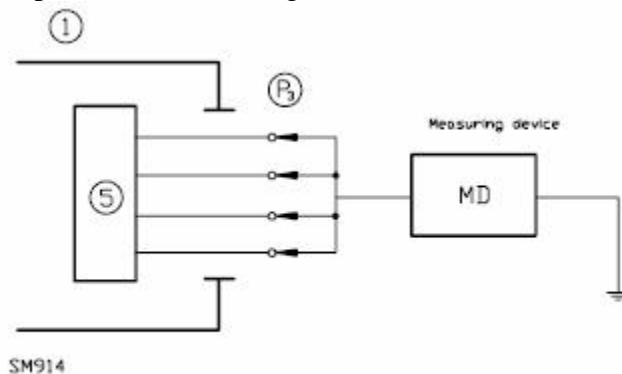

Figure 1

IEC 60601-1 specifies F-Type applied parts as applied parts “isolated from other parts of the equipment to such a degree that no current higher than the patient leakage current allowable in a single fault condition flows if an unintended voltage originated from an external source is connected to the patient, and thereby applied between the applied part and earth.” F-Type applied parts are tested at 110% of the main voltage supply. Basically, the standard refers to this type of applied part as isolated from earth ground. This includes both BF and CF type applied parts but not B Type applied parts. Type BF applied parts are for devices that have conductive contact with the patient, or have applied parts that are fixed in medium or long term contact with the patient. An example of a BF Type applied part is an ECG electrode. Figure 2 illustrates a BF Type applied part set to measure patient auxiliary current. The leads are tied together to represent a particular function such as an ECG electrode. The reference points in this circuit have a floating reference.

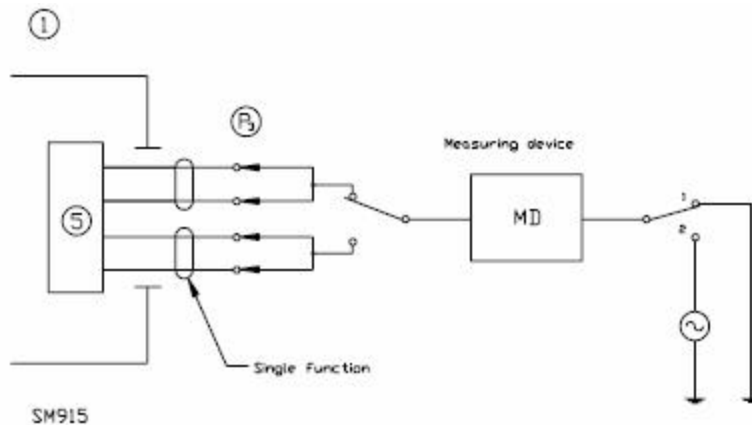

Figure 2

CF Type applied parts are the most restrictive of the three part types. They are required for those applications where the applied part is in direct conductive contact with the heart. Figure 3 below shows a CF Type applied part. Note that the reference in this diagram is also floating.

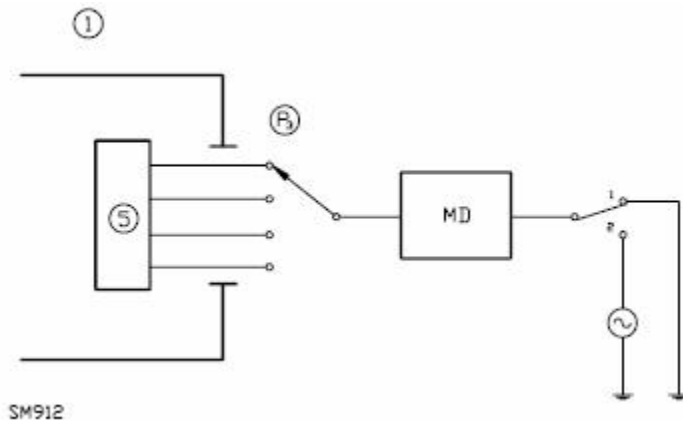
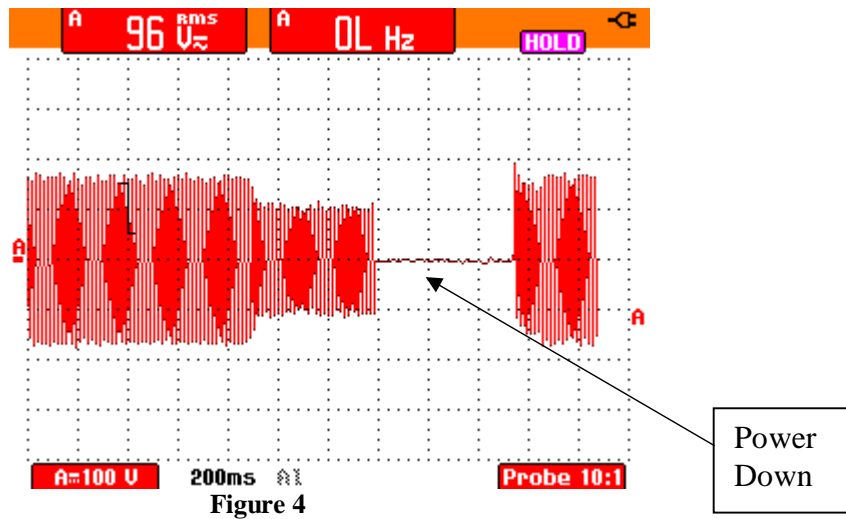

Figure 3

Figures 1-3 illustrate testing configurations for each type of applied part in relation to where the measuring device must be placed during a line leakage test in order to quantify the amount of leakage current that could flow through the human body in the event of a fault condition. These figures are taken from UL 60601-1 Appendix K.

System Configurations

The MedTEST system is available in two base configurations: an OMNIA 8104 connected to a 620L line leakage tester with scanners, or an OMNIA 8106 implemented with scanners. Both systems can perform AC hipot, DC hipot, insulation resistance, continuity, ground bond, functional run, and line leakage tests. Determining an optimal setup for medical device testing depends mainly upon if the medical device is microprocessor based and the amount of current that it draws. Microprocessor based devices generally require a startup time before the unit reaches full functionality. This can pose a problem during line leakage tests due to the fact that many leakage testers power down the device under test in between steps. Figure 4 below shows the power cycle of a standard line leakage tester. As can be seen on the image, the voltage drops to zero once the test is complete and initiates again once the next test starts.



The device under test cannot continuously run during line leakage testing which increases test time. The OMNIA 8106 powers down a device under test in between line leakage test conditions. The OMNIA 8104 used with a 620L allows for continuous run of a device because the 620L controls an advanced software feature which constantly cycles power to the device. Figure 5 illustrates how the 620L continuously cycles power. Notice the small delay in between line leakage tests for the 620L. This delay is 25ms in duration and is not sufficient enough of a time delay to shut down the device under test.

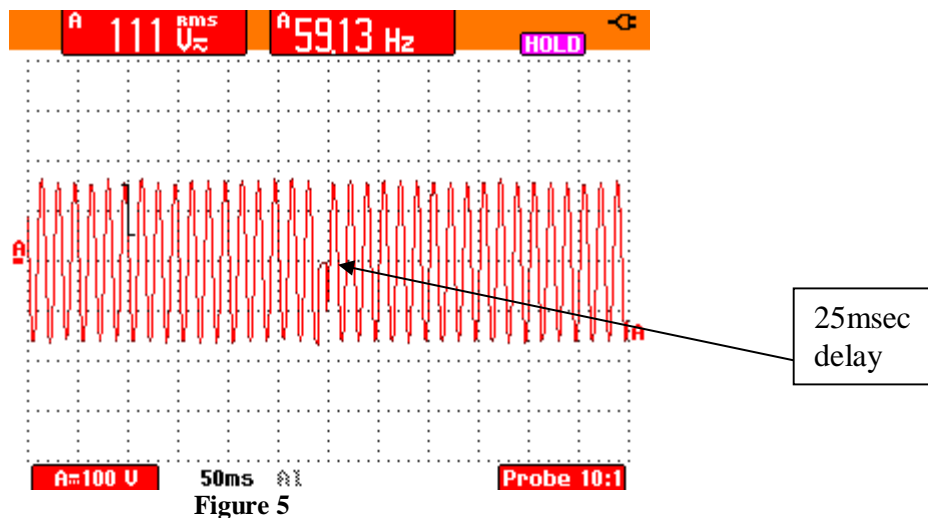

While the OMNIA 8106 can run all test types, the 620L provides functional run and line leakage testing for all fault conditions while the OMNIA 8104 implements all other test types. The other consideration for the device is the amount of current required to power the DUT. For a line leakage test, the OMNIA 8106 can output 15 Amps maximum

continuous current. However, the 620L can output 40 Amps max continuous current. So devices that require a higher current than 15 Amps to run or are microprocessor based must be utilized with a 620L and OMNIA 8104. An OMNIA 8106 used with scanners can be used for any other setup to test multiple leads on medical devices.

Systems of scanner matrices are utilized in order to test multiple points or patient leads. There are two base types of Associated Research Inc. SC6540 scanners: master and slave. Master scanners are controlled remotely via a PC. Slave scanners must be controlled by either a master scanner or a primary test unit such as a hipot or line leakage tester. An individual master scanner can control up to four slave scanners and each scanner can control up to 16 channels. The OMNIA 8104 and 8106 can control up to two 8 channel slaves. The 620L has the ability to control one 8 channel slave. However, implementing multiple master scanners allows for hundreds of test points. The architecture of the scanner channels vary depending upon the test types for the DUT. High current channels must be implemented for ground bond testing on multiple leads because the relays built into the high voltage channels are only rated to handle 100mA current. High voltage channels can be used for any other type of test. Five different scanner options are available, each different in model number and model type. See table 1 below for details:

Table 1

Model	Configuration
HH	16 High Voltage Channels
HG	8 High Voltage Channels, 8 High Current Channels
HN	8 High Voltage Channels
GG	16 High Current Channels
GN	8 High Current Channels

Safety product testing documentation is important for a system that tests multiple patient leads under various conditions. Keeping detailed records of test parameters and results is mandatory for safety testing at many companies. The problem with gathering data on safety tests for multiple leads is the fact that numerous tests and conditions for each test are involved and it can be easy to confuse test parameters. Many companies also have data gathering and sorting programs that must be implemented to record information for any type of automation or testing. The Autoware S8456 program is the software designed to run the automated MedTEST system (See “Interface Communications and Automation” section for details). The software includes options for recording parameters, parameter descriptions, file header descriptions, and results. Descriptions can be added to each individual test to document test methods or line leakage conditions. Data can also be saved in .txt format to interact with data gathering systems. Figure 6 illustrates an example of a hardcopy printout of line leakage test results. Note the headers at the top of the page. Under Step 1, also note that the print preview displays the type of test as well as a step description and all parameter results.

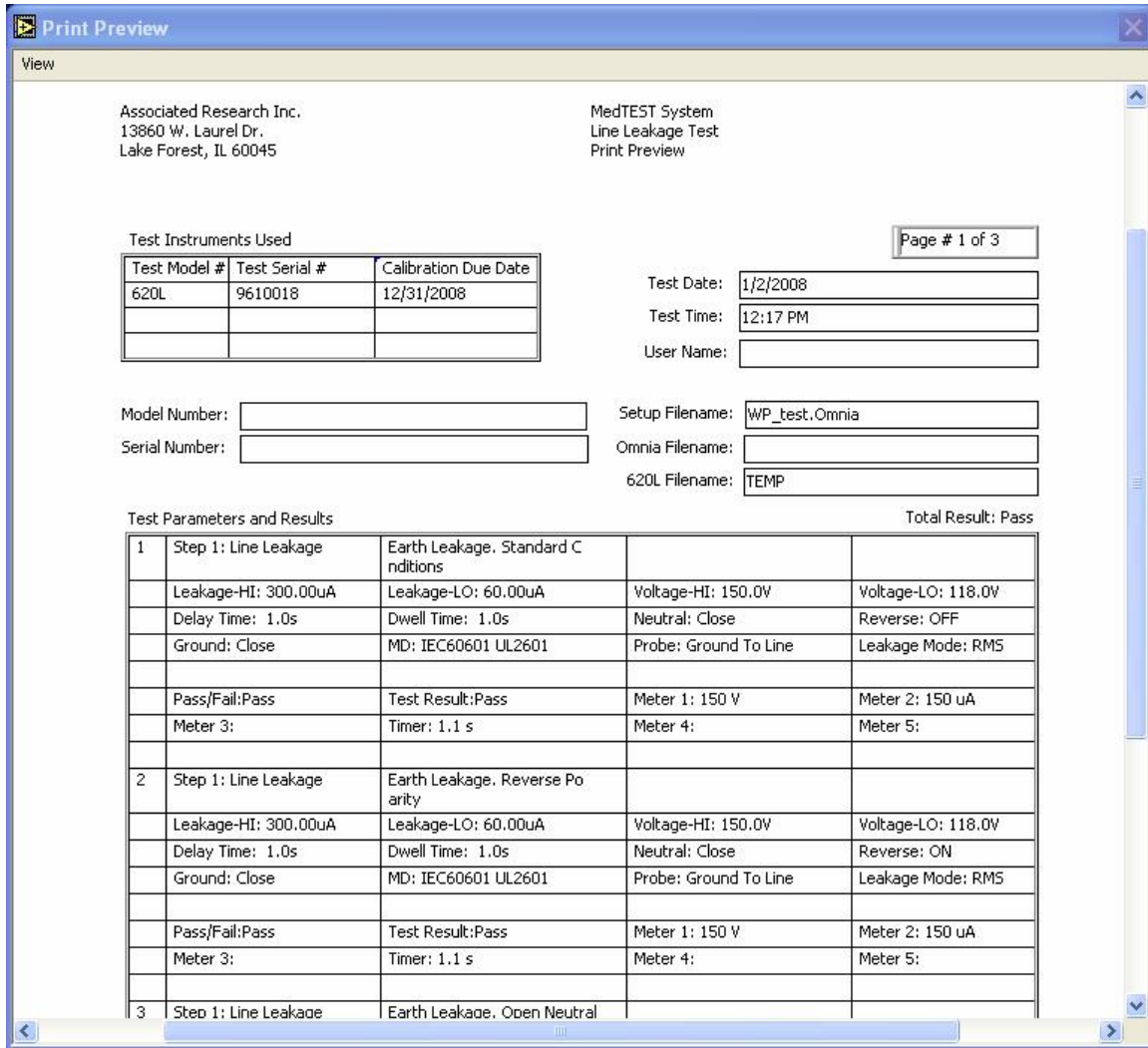

Figure 6

A final consideration for a complete medical testing system deals with a power supply. Most specifications, including IEC 60601-1, require that line leakage testing be performed at 110% of input voltage. This means most line leakage tests in the United States are run at $120V \times 1.10 = 132V$ AC. In the event that a DUT has BF and CF type applied parts, the reference must also be floating. A common way to achieve both parameters is the use of isolation transformers or power sources with a floating reference. An isolation transformer is used to decouple two circuits. It is a means of protecting the operator or patient connected to the DUT from a ground reference as well as providing clean power. A power source with a floating reference can also be used to achieve the same end. The Associated Power Technologies Inc. series of power sources supply clean power with a floating reference and control of input voltage and frequency. The Associated Power Technologies series range in power distribution from 500VA to 4kVA

output and are also available with memory settings. These memory settings can be selected with the 620L line leakage tester. This allows for voltage input on a line leakage test to be automatically set and run via software. The OMNIA 8106 has the ability to share memory settings with a power source. These types of sources allow for 110% of input voltage while adhering to IEC 60601-1 for BF and CF type applied parts.

Although there are two base system configurations, there is a multitude of system combinations available to construct a MedTEST unit. Each unit is chosen and designed to fit the application needs based on the test device, number of patient leads, types of safety tests, and documentation specifications. Each of the units that make up a MedTEST system can be interfaced to a computer for complete automation using software. See Table 2 below for details:

Table 2

	OMNIA 8106 w/ Scanners***	OMNIA 8104 + 620L w/ Scanners
Communication Ports Required (RS-232 interface)*	1 + (1 for each master scanner)	2 + (1 for each master scanner)
Cost	\$15,000 base	\$18,000 base
Continuous Run of DUT	No	Yes
40A DUT Run	No**	Yes
Memory Share Option w/ Power Source	Yes	Yes

*Using GPIB will only require a PC with one communication port. See “Interface Communication” section for details.

** OMNIA 8106 can run 15A max continuous.

***Omnia 8106 can only control line leakage testing for multiple leads through a master scanner. It cannot be done solely through a slave.

Interface Communication and Automation

The two computer interface types available for the MedTEST system are RS-232 communication and GPIB. GPIB, or General Purpose Interface Bus, is also known as IEEE-488 Bus due the fact that it was standardized by the Institute for Electrical and Electronics Engineers. It is a communications bus that utilizes 16 signal wires. The communication method can control up to 15 devices at one time remotely from a PC utilizing a parallel connection. If up to 15 instruments are connected in this fashion, they share a single 8 bit data transfer. Transfer rates range from about one Mbytes/sec on older devices to about 8 Mbytes/sec. The MedTEST can connect to a PC with the use of one

communication port using GPIB. Then all the other devices in the MedTEST system can be “piggy-backed” together for control via the PC. GPIB interfaces, however, only work optimally over distances of 60ft or less. They are also susceptible to noise over longer distances which can cause communication problems on large networks. RS-232 communication works well over long distances but have transfer rates of 20k bits/sec to about 120k bits/sec. A RS-232 port can control one device at a time so multiple communication ports are necessary for the MedTEST system with a RS-232 interface as explained in Table 2.

Interfacing the MedTEST system with a PC allows for complete automation of the system. Tests can be set either by running The Associated Research Inc. Autoware program or the code can be drawn up using a command set. Each Associated Research Inc. device has its own command set for controlling the units. Customers that opt for creating their own code receive the base code in order to construct the tests. Autoware supports both RS-232 and GPIB interfaces. A new version of Autoware, V 2.06, is designed to specifically handle the MedTEST system and its applications. For a 620L and 8104 base configuration, Autoware allows the two units to run as a complete system or individually as single devices which creates flexibility in design. Autoware V 2.06 also includes additional printing and documentation capabilities as mention in the “System Configurations” section.

Conclusion

The automation of the MedTEST system alleviates concerns of operator interference because tests can be set and run without the need for switching connections or changing parameters. Autoware also includes password protected security settings which create varying levels of access to system setups. Since the system also includes a continuous run feature to allow microprocessor based devices to boot-up and run, test time is considerably reduced. These factors along with flexibility in MedTEST system configurations make testing multiple leads medical devices possible.